

**REVIEW ON DIRECT TORQUE CONTROL IN
MULTI-LEVEL INDUCTION MOTOR DRIVES**

Dr. Amita Mahor,
Professor & Head,
Electrical Department,
NIIST, BPL

M. Ashfaque Khan,
Associate Professor,
Electrical Department,
NIIST, BPL

Niket Vashi,
MTech Scholar,
Electrical Department,
NIIST, BPL

Abstract:

The paper presents an overview of direct torque control (DTC) an efficient torque control technique for induction machine. The DTC offers elimination of PI regulators, variable transformations and pulse width modulated signal generators, providing superior control over motor torque in steady state and transient conditions. With ever improving reliability and performance of digital devices, digital control techniques are fast catching popularity due to software flexibility and low cost. Intelligent control techniques like neural networks (NN) and fuzzy logic based DTC are also being preferred and Field Programmable Gate Arrays (FPGAs) are a providing platform for highly efficient implementation to high bandwidth control systems.

Keywords: Vector Modulation, Multilevel Inverter, Direct Torque Control, Field Programmable Gate Array, Induction Motor, Space.

Nomenclature

v_s	Stator voltage vector.
φ_s, φ_r	Stator, rotor flux vector.
T_e	Electromagnetic torque.
R_s	Stator resistance.
L_s, L_r	Stator (rotor) inductance.
L_m	Magnetizing inductance.
σ	Total leakage coefficient, $\sigma = 1 - L_m^2 / L_s L_r$.
θ_{sr}	Angle between stator, rotor flux vectors.
p	Pole pair.

1. INTRODUCTION

The Induction Machine (IM) has been widely used in industries due to its relative cheapness, low maintenance and high reliability [1]. The control of IM variable speed drives [2], [3] often requires control of machine currents, which is achieved by using the Voltage Source Inverter (VSI). The scalar control of IM drives with inverters is widely used in low cost applications. The main advantage of v/f control is its simplicity and for this reason it has been traditionally implemented using low cost microcontrollers. For applications requiring higher dynamic performance Field Oriented Control (FOC) is preferred. The main issue relating FOC drives is the difficulty in obtaining the decoupled machine flux and torque [4]. The indirect FOC or sensorless FOC in IM drives provides an edge over conventional control but requires complex estimation procedures and is preferred in high performance critical applications. Another control concept different from FOC, yielding quick response and high efficiency in IM has been discussed in [5]. The key features of this method are

- i) The proposed scheme is based on limit cycle control of both flux and torque using optimum PWM output voltage; a switching table is employed for selecting the optimum inverter output voltage

vectors so as to obtain quick torque response, for lowest possible inverter switching frequency and lowest possible harmonic losses .

ii) Controlling amplitude of flux in accordance with the torque command can offer higher efficiency under steady-state.

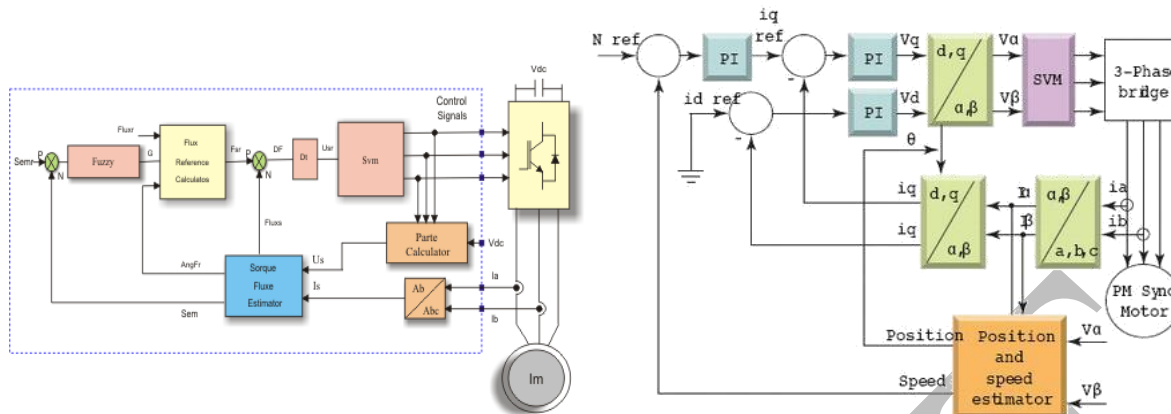

Figure 1 Torque control schemes. (a) Field-oriented control. (b) Direct torque control

Figure 1(a) shows typical system configuration employing FOC. The system usually employs a position sensor to drive a rotating reference frame transformation, which generates the phase current commands for the current controlled inverter. The primary current reference i^* is calculated from the flux command ψ^* and the torque command T^* by using an estimator. The control equation for the estimator contains motor parameters which vary with the winding temperatures and the flux saturation level of the iron core. Fig. 1 (b) shows a schematic diagram of the proposed control scheme. The instantaneous values of the flux and the torque are calculated from primary variables and controlled by using an optimum switching table. Therefore, it can achieve not only the fastest torque response but also the lowest harmonic losses and acoustic noise. In [8] the performance of the DTC and FOC schemes is evaluated in for torque and current ripples and transient response for step torque command variations. The analysis has been carried out where effects introduced by hardware implementation is not present.

Table 1: Torque Response Settling Time [2]

Speed	FOC	DTC
1200	3.8 ms	1.8ms
600	1.8 ms	0.7 ms
100	1.7 ms	0.5 ms

DTC might be preferred for high dynamic applications [9], but, on the other hand, shows higher current and torque ripple, although this drawback can be partially compensated by SVM based DTC scheme. The DTC scheme is relatively simple to implement, requiring a very small computational time when compared to FOC (Table 1). In this review, a grouping of papers based on the control strategy is attempted. DTC based on intelligent control techniques like fuzzy logic and neural network is mainly used to reduce torque ripples. DSP and FPGA based DTC are improving the performance of drives.

DTC is suitable for induction motor as it takes into account inverter stage utilising a few machine parameters, and is more robust to machine parameter estimations against field-oriented control. The papers [7] and [8] present a formal and theoretical derivation for a singular perturbation and non-linear control tools respectively. The derivation elaborates relationship between DTC performance and machine characteristics and concludes that low-leakage machines are expected to perform better with direct torque control. The challenging operating regions are predicted and explicit conditions to guarantee stability are presented. A variety of techniques, different in concept are as follows:

- i. switching-table-based hysteresis DTC,
- ii. direct self control,
- iii. constant switching frequency DTC
- iv. Space-vector modulation (DTC-SVM).

2. Concern Areas in DTC

The main problems associated with DTC is torque ripple, Many papers presented different approaches to minimize the torque ripples. In [11] flux linkage, electromagnetic torque are controlled directly by look-up table through a switching vector. Although, the selected vector is not always best choice since only the sector is considered and the flux linkage space vector lies without considering its accurate location. The look-up table in the DTC is replaced by a minimum-distance vector selection scheme to minimize the flux and torque ripples over a fixed sampling period. A new direct self-control (DSC) scheme for IM drives using the stator voltage third harmonic component in order to estimate the air-gap flux and the torque as well as to synchronize the supply voltage vector.

Compared to previous DSC schemes this model is independent of motor parameter deviation, specifically stator resistance thus showing better performances at low speeds for a 1.5-kW induction motor drive. A constant switching frequency torque controller [12] is proposed to replace the conventional hysteresis-based controller. The proposed controller is shown to be capable of reducing the torque ripple and maintaining a constant switching frequency. In [13] the proposed HPWM method is developed based on notion of stator flux ripple which can be used as a measure of ripple in the line current. The mean square flux ripple, over a cycle is derived for each switching sequence and this analysis together with the total harmonic distortion performance of each sequence is used to develop the HPWM method for induction motor drives. A sliding mode controller [14] investigated which features in very low flux and torque ripple to guarantee electromagnetic torque and stator flux to closely track its reference signal, the e-m torque sliding mode variable and stator flux sliding mode variable were selected separately. The observer gain matrix is obtained by solving linear matrix inequality (LMI) using LMI Toolbox in MATLAB.

3. Multilevel Cascaded H-Bridges

The cascaded H-bridge inverter contains power conversion units, each supplied by an isolated dc source. The advantage of this topology lies in modulation, control, and protection of each bridge. Fig. 1 shows topology of a cascade inverter with isolated dc- sources. An output voltage waveform is obtained by summing the bridges output voltages.

$$v_o(t) = v_{o,1}(t) + v_{o,2}(t) + \dots + v_{o,N}(t) \quad (1)$$

Here; N is the number of cascaded bridges. The inverter output voltage $v_o(t)$ may be determined from the individual cells switching states as;

$$v_o(t) = \sum_{j=1}^N (\mu_j - 1) V_{dc,j}, \quad \mu_j = 0, 1, \dots \quad (2)$$

If all dc-voltage sources are equal to V_{dc} , the inverter is referred as a symmetric multilevel inverter. The effective number of output voltage levels n in symmetric multilevel inverter is related to the cells number by

$$n = 1 + 2N \quad (3)$$

The maximum output voltage $V_{o,Max}$ is then

$$V_{o,MAX} = NV_{dc}.$$

The number of unique voltage levels for a factor 2 or 3 is given as;

$$\begin{cases} n = 2^{N+1} - 1, & \text{if } V_{dc,j} = 2^{j-1} V_{dc}, \quad j = 1, 2, \dots, N \\ n = 3^N, & \text{if } V_{dc,j} = 3^{j-1} V_{dc}, \quad j = 1, 2, \dots, N. \end{cases} \quad (4)$$

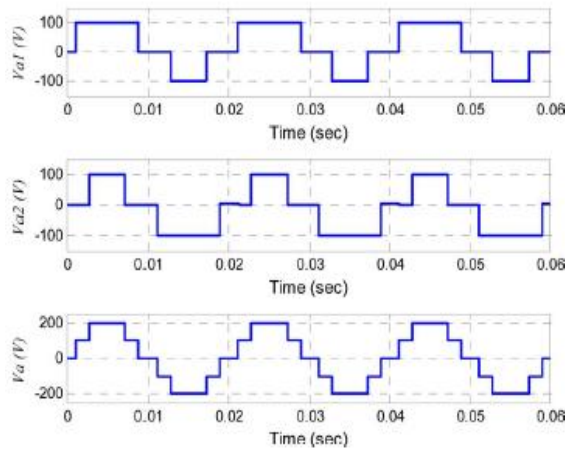

Figure 2: Five Level Symmetrical multilevel inverter output

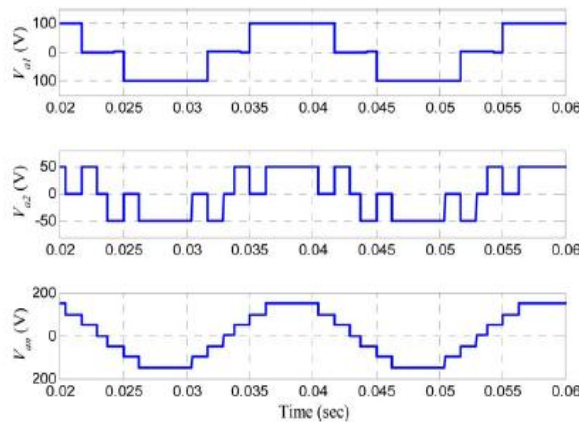

Figure 3: Seven Level Asymmetrical multilevel inverter output

The maximum output voltage of N cascaded multilevel inverters is given as;

$$V_{o,MAX} = \sum_{j=1}^N V_{dc,j} \tag{5}$$

Table 2: Multilevel Inverter Mutual Comparison

	Symmetrical Inverter	Asymmetrical Inverter	
		Binary	Ternary
N	2N+1	$2^{N+1}-1$	3^N
DC sources	N	N	N
Number of Switches	4N	4 N	4 N
V_{oMAX} [pu]	N	2^N-1	$(3^{N+1}-1)/2$

4. Fundamental Principle Of DTC

The stator flux vector an induction motor is related to the voltage and current vectors by

$$\frac{d\phi_s(t)}{dt} = v_s(t) - R_s i_s(t) \tag{6}$$

If stator resistance is neglected and v_s is held constant for a sample period then

$$\Delta\phi_s(t) = \phi_s(t) - \phi_s(t - \Delta t) = \int_{t-\Delta t}^t v_s \Delta t \tag{7}$$

Since the stator flux can be changed quickly while the rotor flux rotates slowly, the angle between vectors θ_{sr} can be controlled directly by v_s .

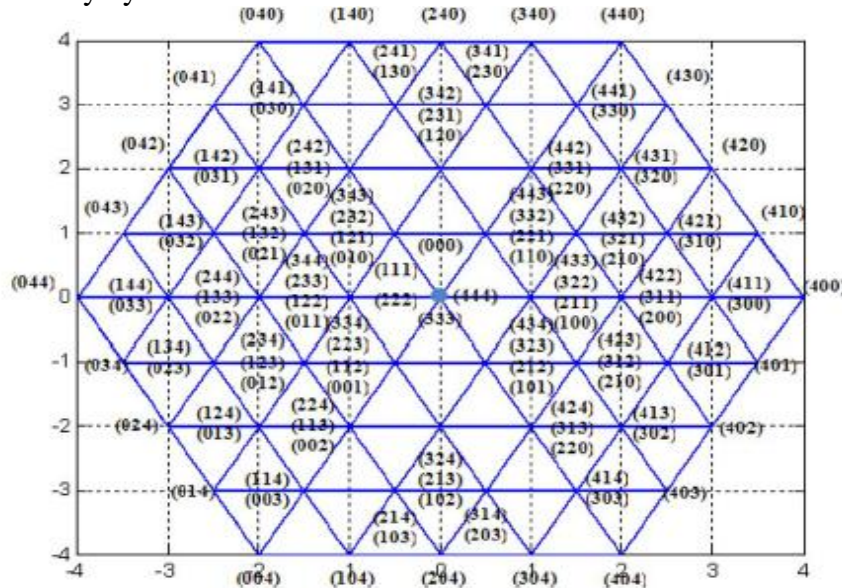

Fig. 4 Voltage vectors of various states of the symmetrical five-level inverter

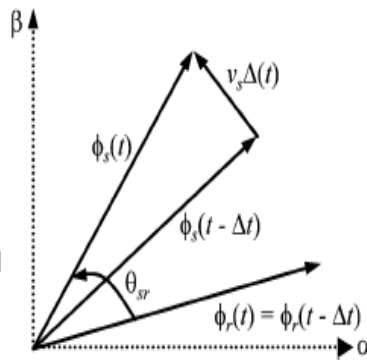

Fig5: Dependence of v_s over ϕ_s during a simple interval Δt

As the electromagnetic torque developed by an induction motor can be expressed by

$$T_e = \frac{3}{2} p \frac{L_m}{\sigma L_s L_r} \phi_s \phi_r \sin \theta_{sr} \tag{8}$$

Table 3: Lookup Table For Voltage-Vector-Selection

Sector	$sign(e_\phi^k, e_T^k)$			
	(+,+)	(+,-)	(-,+)	(-,-)
1	V2	V6	V3	V5
2	V3	V1	V4	V6
3	V4	V2	V5	V1
4	V5	V3	V6	V2
5	V6	V4	V1	V3
6	V1	V5	V2	V4

Change in θ_{sr} due to the action of v_{s} allows direct and quick change in torque, this principle is used in DTC to achieve the desired torque response, by applying a suitable stator voltage vector to correct the flux trajectory

5. Conclusion

This paper presents a comprehensive study for a DTC induction motor drive, focusing on DTC induction motor drive technology. The study suggests that an asymmetrical configuration of multilevel inverters provides nearly sinusoidal voltages with very low distortion, using less switching devices. In addition, torque ripples are greatly reduced. Asymmetrical multilevel inverter enables a DTC solution for high-power induction motor drives, not only due to the higher voltage capability provided by multilevel inverters, but mainly due to the reduced switching losses and the improved output voltage quality, which provides sinusoidal current without output filter.

REFERENCES

1. Nalin Kant Mohanty, Ranganath Muthu and M. Senthil Kumar, "A survey on controlled AC electrical drives", *International Journal of Electrical and Power Engineering*, 3(3), 2009, pp.175-183
2. R. Toufouti, S. Meziane, H. Benalla, "Direct torque control for induction motor using intelligent techniques", *Journal of Theoretical and Applied Information Technology*, 2007, pp.35-44.
3. Y. Srinivasa Kishore Babu and G. Tulasi Ram Das, "Improvement in direct torque control of induction motor using fuzzy logic duty ratio controller", *ARPN Journal of Engineering and Applied Sciences*, Vol.5, No.4, April 2010, pp.68-74.
4. Soufien Gdaim, Abdellatif Mtibaa, Mohamed Faouzi Mimouni, "Direct torque control of induction machine based on intelligent Techniques", *International Journal of Computer Applications* (0975 - 8887), Vol.10, No.8, Nov. 2010, pp.29-35.
5. K. Ramani, A. Krishnan, "Simulation based direct torque control of induction motor with stator flux reimbursement", *International J. of Recent Trends in Engineering*, Vol.2, No.6, Nov.2009, pp.10-12.
6. Jagadish H. Pujar, S.F. Kodad, "AI based direct torque fuzzy control of AC drives", *International Journal of Electronic Engineering Research*, Vol.1, No.3, 2009, pp.233-244.
7. Sarat Kumar Sahoo, G. Tulasi Ram Das and Vedam Subrahmanyam, "Sensor fault tolerant of direct torque control in induction motor drives", *International Journal of Recent Trends in Engineering*, Vol.2, No.6, Nov.2009, pp.44-49
8. Yongchang Zhang, Jianguo Zhu, Zhengming Zhao, Wei Xu, and David G. Dorrell, "An improved direct torque control for three-level inverter - fed induction motor sensorless drive", *IEEE Transactions on Power Electronics*, Vol.27, No.3, March 2012.
9. M. Nasir Uddin, Muhammaed Hafeez, "FLC -based DTC scheme to improve the dynamic performance of an IM drive", *IEEE Transactions on Industry Applications*, vol.48, No.2, March/April 2012.
10. Rajesh Kumar, R.A. Gupta, S.V. Bhangale, Himanshu Gothwal, "Artificial neural network based direct torque control of induction motor drives", *IETECH Journal of Electrical Analysis*, Vol.2, No.3, pp.159-165, 2008.
11. Hamid Yantour, Janah Saadi, Ahmed Khoumsi, "A hybrid system based approach to direct torque control (DTC) of induction motors", *18th Mediterranean Conference on Control and Automation*, Morocco, pp.327-332, June 23-25, 2010
12. C.L. Toh, N.R.N. Idris, A.H.M. Yatim, "Design and implementation of TMS320C31 DSP and FPGA for conventional direct torque control (DTC) of induction machines", *World Academy of Science, Engineering and Technology*, 2009, pp.448-453.
13. Sarat Kumar Sahoo, G. Tulasi Ram Das, Vedam Subrahmanyam, "VLSI design approach to high performance direct torque control of induction motor drives", *World Journal of Modelling and Simulation*, Vol.4, No.4, Aug.2008, pp.269-276.
14. Jacek Lis, Czeslaw T. Kowalski, Teresa Orłowska - Kowalska, "Sensorless DTC control of the induction motor using FPGA", *IEEE*, 2008, 1914-1919.
15. Marcian N. Cirstea, Andrej Dinu, "A VHDL holistic modeling approach and FPGA implementation of a digital sensorless induction motor control scheme", *IEEE Transactions on Industrial Electronics*, Vol.54, No.4, pp.1853-1864, Aug.2007.
16. Sarat Kumar Sahoo, G. Tulasi Ram Das, and Vedam Subrahmanyam, "Implementation and simulation of direct torque control scheme with the use of FPGA circuit", *ARPN Journal of Engineering and Applied Sciences*, Vol.3, No.2, April 2008, pp.48-54.
17. Masood Hajian, Jafar Soltani, Gholamreza Arab Markadeh and Saeed Hosseinnia, "Adaptive non linear direct torque control of a sensorless IM drives with efficiency optimization", *IEEE Transactions on Industrial Electronics*, Vol.57, No.3, March 2010, pp.975-985.

18. Kuo – Kai Shyu, Juu-Kuh Lin, Van – Truongphom Ming – Ji Yang and Te –Wei Wang, “Global minimum torque ripple design for direct torque control of induction motor drives”, *IEEE Transactions on Industrial Electronics*, Vol.57, No.9, Sep. 2010, pp.3148-3156.
19. Detian Sun, “Sliding mode direct torque control for induction motor with robust stator flux observer”, *International Conference on Intelligent Computation Technology and Automation, ICICTA, IEEE*, 2010, pp.348-351.
20. Jef Beerten, Jan Verdeccken, Johan Driesen, “Predictive direct torque control for flux and torque ripple reduction”, *IEEE Transactions on Industrial Electronics*, Vol.57, No.1, Jan. 2010, pp.404-412.
21. Farid Khoucha, Soumia Mouna Layoun, Khoudir Marouni, Adelaziz Kheloui and Mohamed El Hachemi Benbouzid, “Hybrid cascaded H – Bridge multilevel-inverter induction motor drive direct torque control for automotive applications”, *IEEE Transactions on Industrial Electronics*, Vol.57, No.3, March 2010, pp.892-899.
22. Libo Zheng, John E. Fletcher, Barry W. Williams, Xiangning He, “A novel direct torque control scheme for a sensorless five phase induction motor drive”, *IEEE Transactions on Industrial Electronics*, Vol.58, No.2, February 2011.
23. Jef Beerten, Jan Verdeccken, Johan Driesen, “Predictive direct torque control for flux and torque ripple reduction”, *IEEE Transactions on Industrial Electronics*, Vol.57, No.1, Jan. 2010, pp.404-412.

IJERMT